

Figure 1 Drill Press Vice assembly

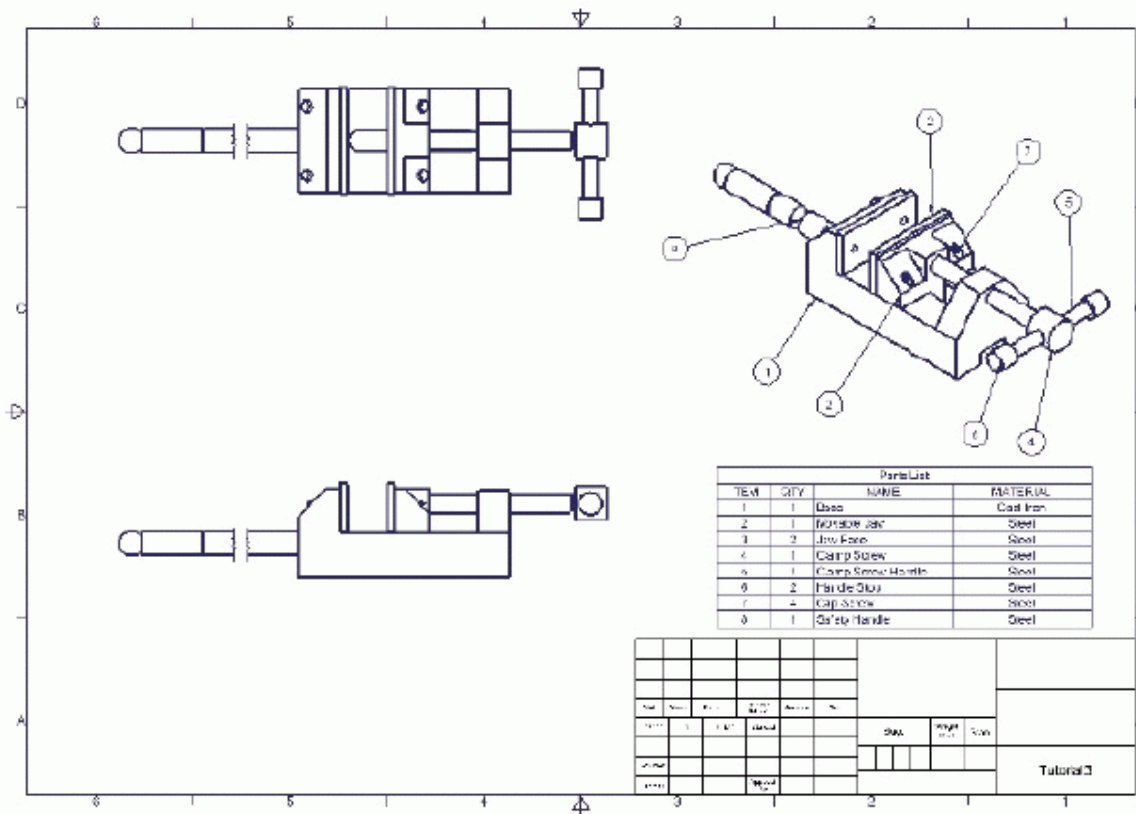

Figure 2 Drawing views of the Drill Press Vice assembly

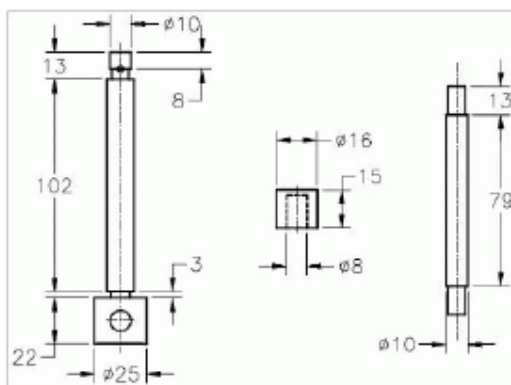

Figure 3 Dimensions of the Clamp Screw, the Handle Stop, and the Clamp Screw Handle

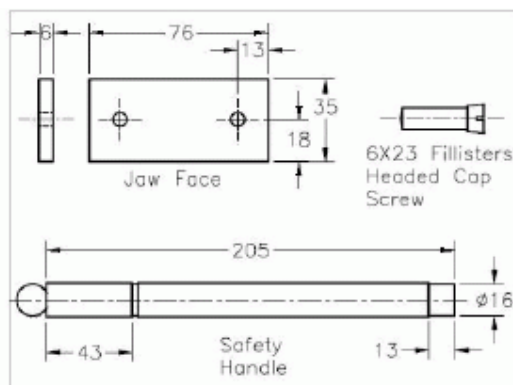

Figure 4 Dimensions of the Jaw Face, the Cap Screw, and the Safety Handle

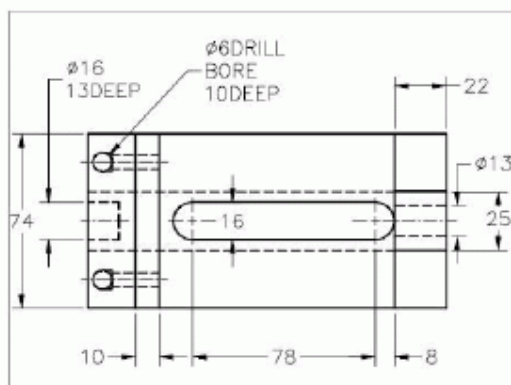

Figure 5 Top view of the Base

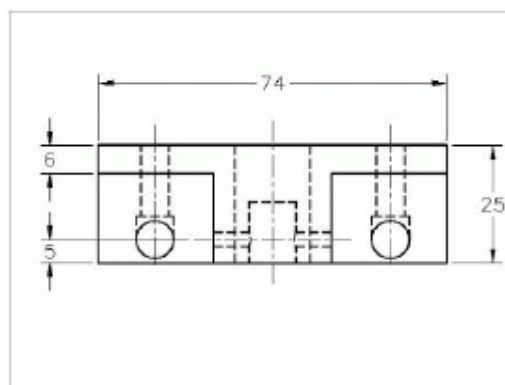

Figure 6 Top view of the Movable Jaw

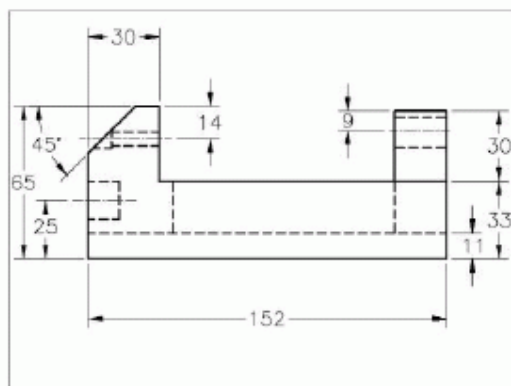

Figure 7 Front view of the Base

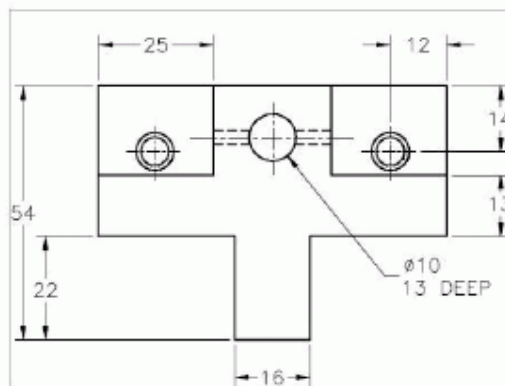

Figure 8 Front view of the Movable Jaw